

Energy Economics, Winter Semester 2023-4

Lecture 4: Electricity Markets

Prof. Tom Brown, Philipp Glaum

[Department of Digital Transformation in Energy Systems](#), Institute of Energy Technology, TU Berlin

Unless otherwise stated, graphics and text are Copyright © Tom Brown, 2021-4. Graphics and text for which no other attribution are given are licensed under a Creative Commons Attribution 4.0 International Licence. 

1. Introduction to electricity markets
2. Electricity consumption
3. Electricity generation
4. Matching consumption to generation
5. Merit order effect

Introduction to electricity markets

Electricity markets have several important differences compared to other commodity markets.

At every instant in time, consumption must be **balanced** with generation.

E.g. if you throw a switch to turn on a light, somewhere a generator will be increasing its output to compensate.

If the power is not balanced in the grid, the power supply will collapse and there will be blackouts.

It is not possible to run an electricity market for every single second, for practical reasons (the network must be checked for stability, etc.).

So electricity is traded in blocks of time, e.g. hourly, 14:00-15:00, or quarter-hourly, 14:00-14:15, well in advance of the time when it is actually consumed (based on forecasts).

Additional markets trade in balancing power, which step in if the forecasts are wrong.

What happens when things go wrong

In November 2006, the continental European system split into three parts. Since before the split 10 GW was being transferred from East to West, in the West there was a generation deficit, which caused a frequency drop, while in the East there was an oversupply, causing a frequency spike.

- Area 1 under-frequency
- Area 2 over-frequency
- Area 3 under-frequency

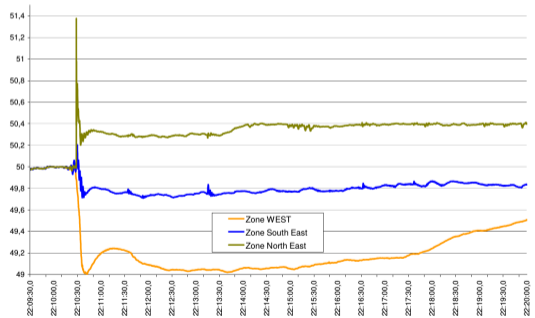
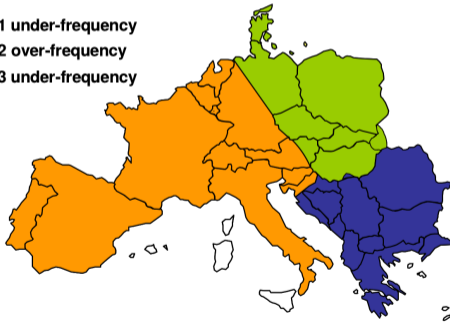

Grid takes electricity from generators to consumers. Long distance transport: **transmission network** at high voltages (> 110 kV). Shorter distance transport: **distribution network** at lower voltages (≤ 110 kV). In houses usually 230 V.

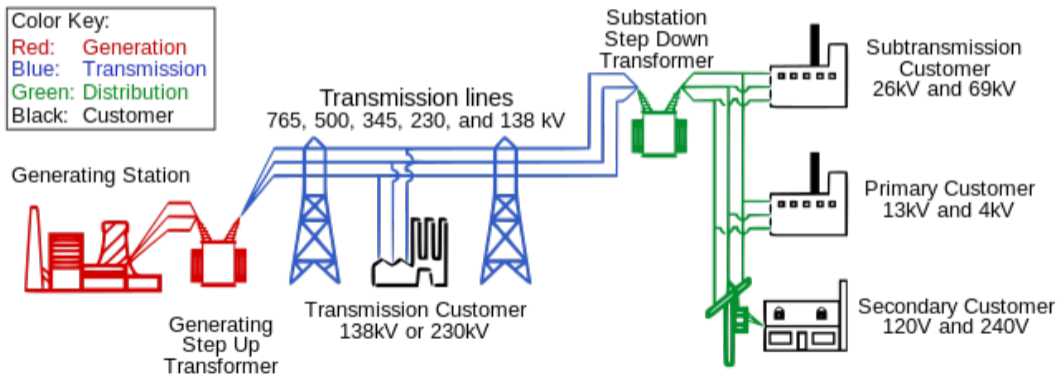

The European transmission network is mostly at 220 kV (green) and 380 kV (red). Purple lines are undersea high voltage direct current (HVDC) cables.

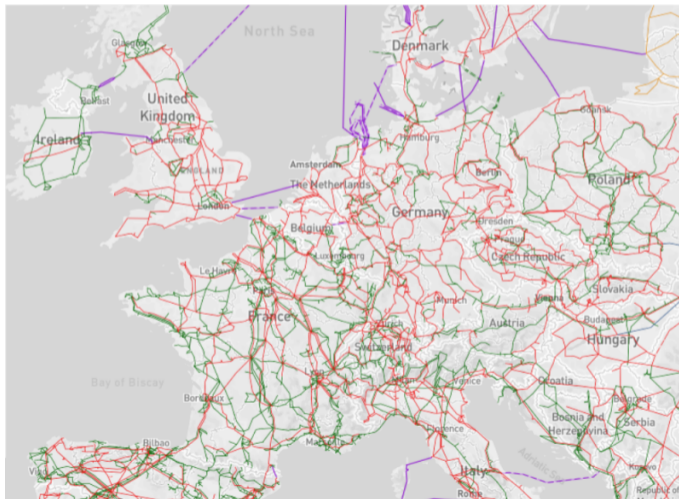

In parallel there is a **commercial infrastructure** to take money from consumers to generators.

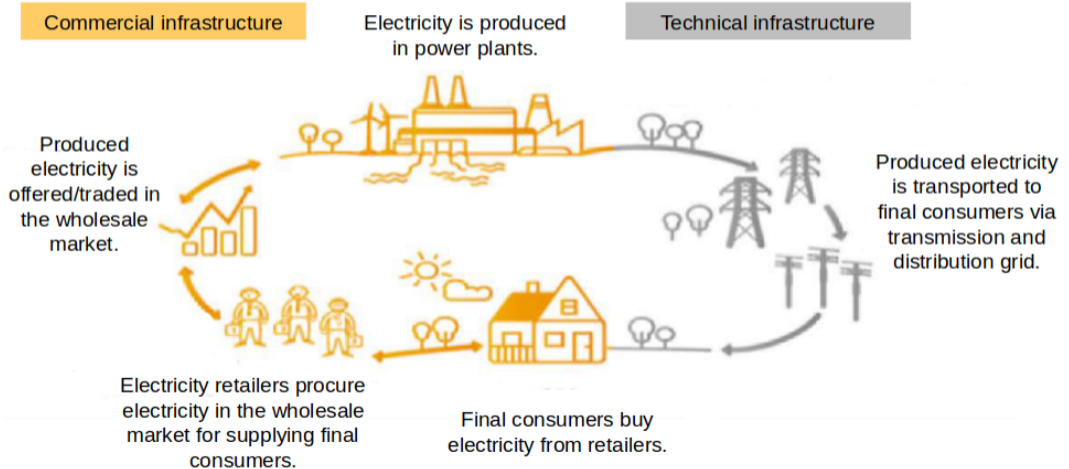

Historically in Europe and still in many regions of the world, a **vertically-integrated** company (often state-owned) performed all the activities from generation to transmission to retail for final consumers.

Since early 1990s in Europe: **liberalisation** (deregulation/restructuring/unbundling)

- introduction of **competition** to the activities where competition is considered possible (generation, retail)
- state regulation in the areas of **natural monopoly** (networks)

Vertically-integrated utilities before liberalisation:



Transmission system operators 2021:



Natural monopolies occur in industries for which it is only economically efficient to have a single provider due to economies of scale (decreasing average costs with increasing scale of production).

Electricity transmission and distribution is a decreasing cost industry: Duplicating the grid is economically inefficient.

Yet, natural monopolies - like monopolies in general - tend to overcharge and underserve.

Solution: **state regulation**, e.g. by German Federal Network Agency (Bundesnetzagentur) that regulates what costs can be passed to consumers.

Competitive conditions for electricity generation and retail can be created by state regulation aiming at:

- **Costs transparency** \Rightarrow prevent cross-subsidies (e.g. allocating costs from competitive activities to grid operation)
- **Non-discriminatory access** to the grid (e.g. grid connection and transmission/distribution services)

Unbundling is a set of organisational measures to separate transmission and distribution networks from generation and retail activities.

It aims at ensuring independence of a grid operator from other activities in a vertically integrated company and at preventing discrimination of other market participants.

- **Ownership:** grid is operated by an entity with a separate ownership control
- **Legal:** separate legal entity operates a regulated activity
- **Accounting:** separate book-keeping for regulated activities
- **Management:** personal requirements for members of management bodies of a grid operator
- **Operational:** TSO/DSO should have sufficient resources for operations (rather than relying on other parts of the vertically integrated undertaking). Restrictions for shared services (HR, IT, legal, finance etc.)
- **Informational:** non-disclosure of commercially sensitive information from regulated activities (grid operation) to other units; otherwise - non-discriminatory disclosure to all market participants

1996: 1st Energy Package – Directive 96/92/EC

- accounting and informational unbundling for vertically integrated undertakings (VIU)

2003: 2nd Energy Package – Directive 2003/54/EC

- legal, management, operational and informational unbundling

2009: 3rd Energy Package – Directive 2009/72/EC

- Transmission System Operator (TSO): ownership unbundling; alternatively ISO or ITO model

- Independent System Operator (ISO): while the VIU keeps ownership control, an independent system operator operates the grid, incl. decisions on third-party access and investment planning

- Independent Transmission Operator (ITO): TSO remains part of VIU but is subject to additional stricter requirements for effective independence

- Distribution Service Operator (DSO): legal, management, operational and informational unbundling

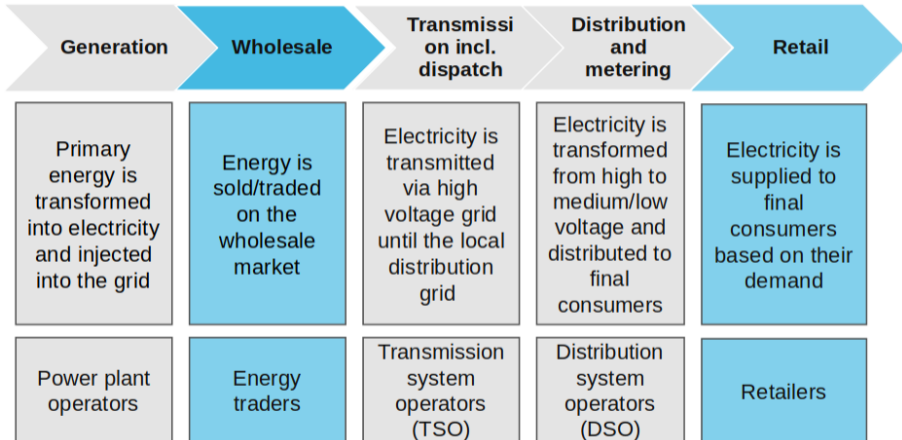

Competitive versus natural monopoly actors

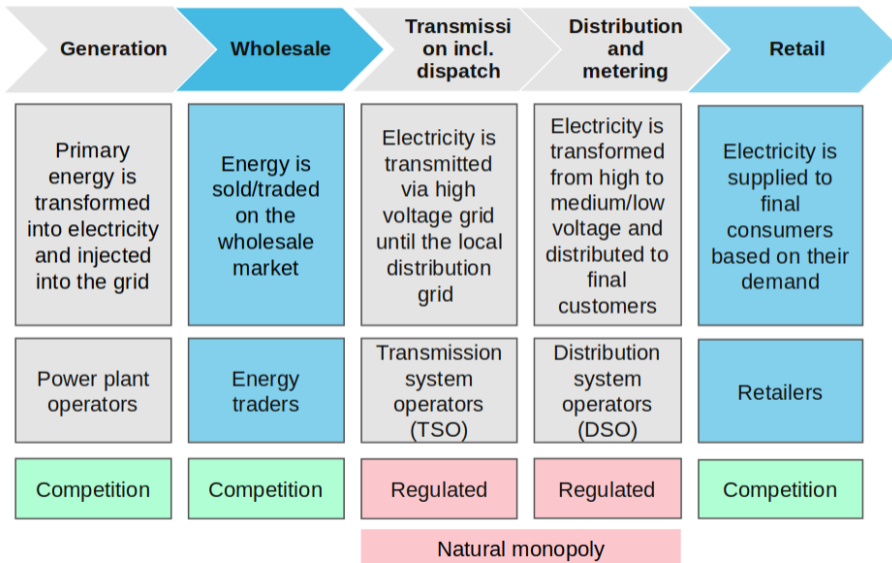

Objectives of an electricity market design:

- **Short-run efficiency**, i.e. making the best use of existing resources (generation capacities etc.)
- **Long-run efficiency**, i.e. promoting efficient investment into new resources (generation assets, grid, storage etc.)
- **Reliability**, i.e. reserves for satisfying demand at times of generation shortage
- **Sustainability**, i.e. preserving health, environment and climate

We will consider four variations:

- Single buyer
- Power pool
- Free wholesale competition
- Fully liberalised market with retail competition

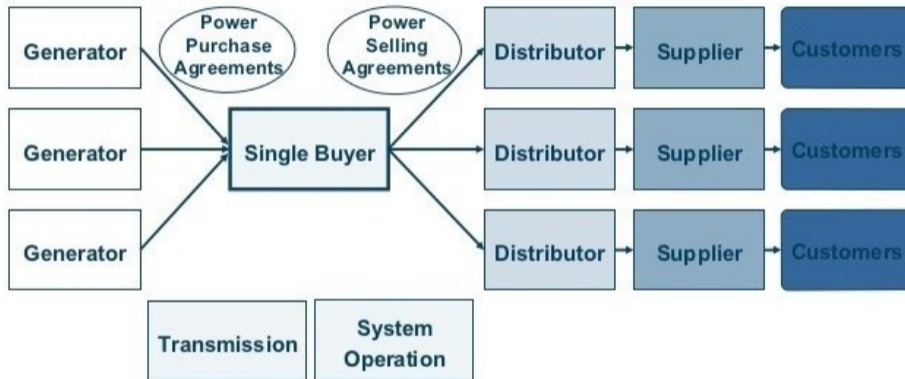

No access arrangements and direct trading between generators and distributors/suppliers

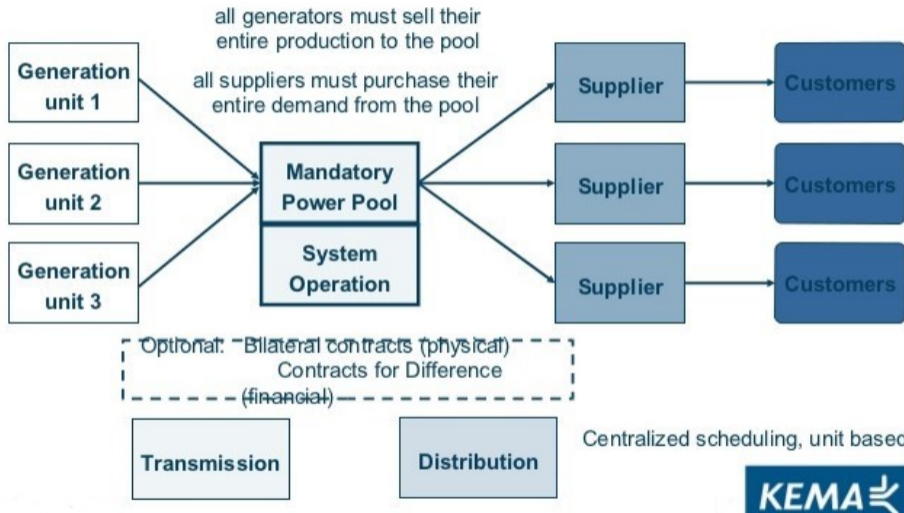

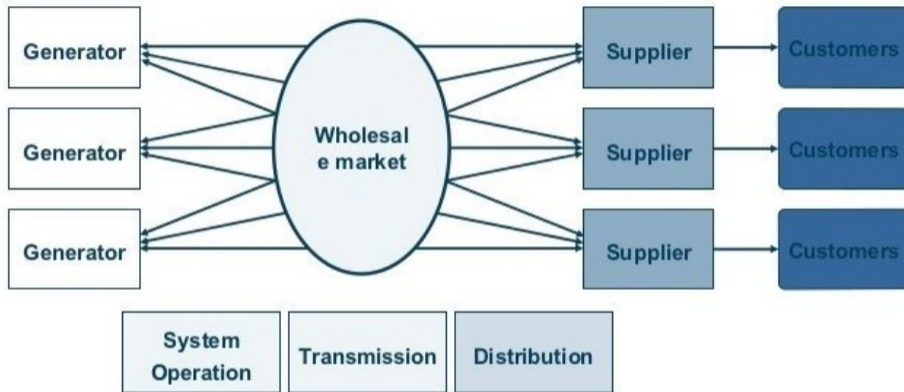

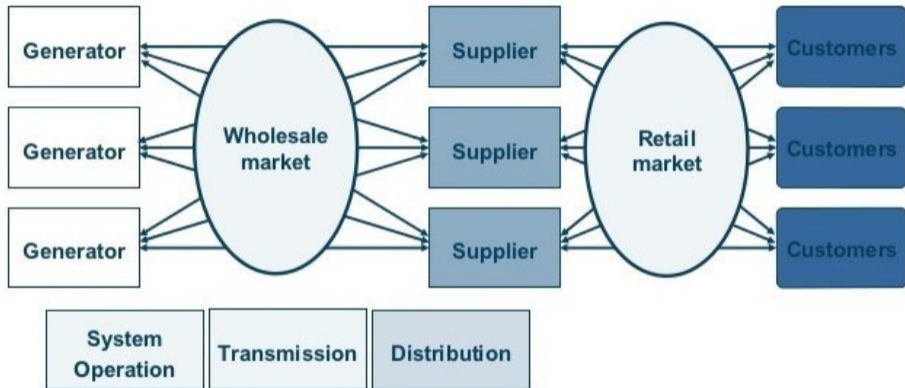

Electricity consumption

Electricity is a versatile form of energy carried by electrical charge which can be consumed in a wide variety of ways (with selected examples):

- Lighting (lightbulbs, halogen lamps, televisions)
- Mechanical work (hoovers, washing machines, electric vehicles)
- Heating (cooking, resistive room heating, heat pumps)
- Cooling (refrigerators, air conditioning)
- Electronics (computation, data storage, control systems)
- Industry (electrochemical processes)

Compare the convenience and versatility of electricity with another energy carrier: the chemical energy stored in natural gas (mostly methane), which can only be accessed by burning it.

At full power, the following items consume:

Item	Power
New efficient lightbulb	10 W
Old-fashioned lightbulb	70 W
Single room air-conditioning	1.5 kW
Kettle	2 kW
Factory	~1-500 MW
CERN	200 MW
Germany total demand	35-80 GW

The discrete actions of individual consumers smooth out statistically if we aggregate over many consumers.

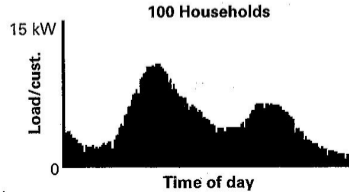
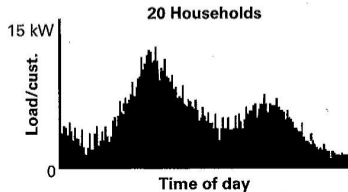
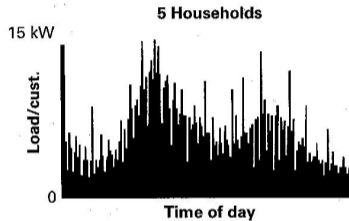
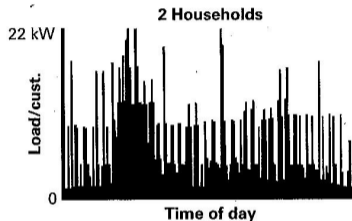

The national German load curve includes residential, services and industry demand.

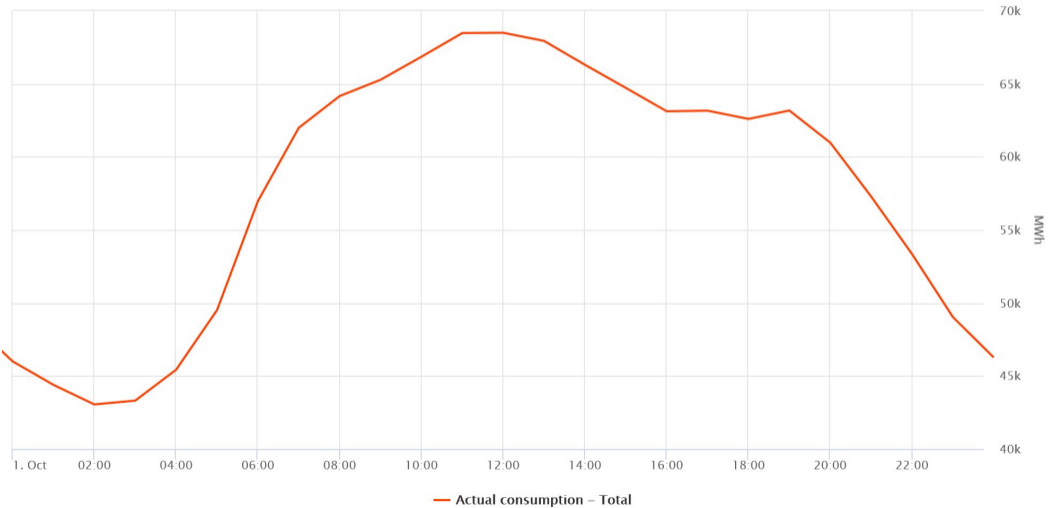

National yearly load curve

The Germany load curve (around 500 TWh/a) shows **daily**, **weekly** and **seasonal** patterns; religious festivals are also visible.

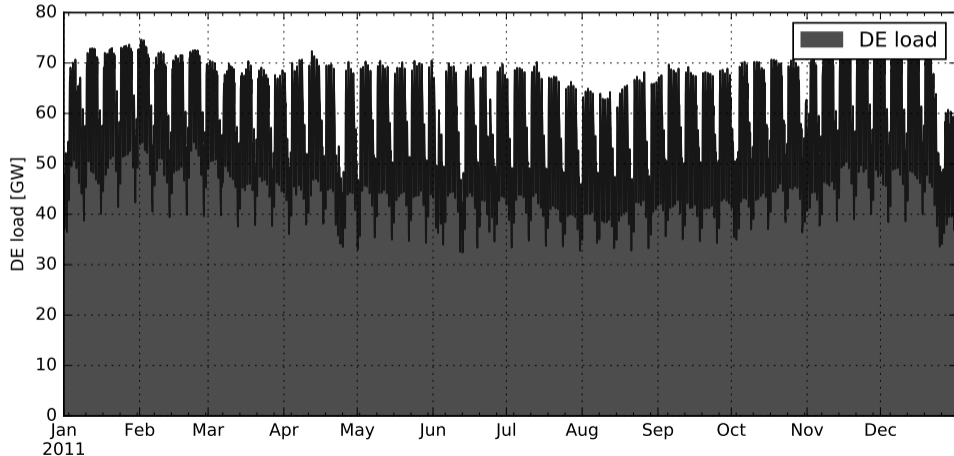

For some analysis it is useful to construct a **duration curve** by stacking the hourly values from highest to lowest.

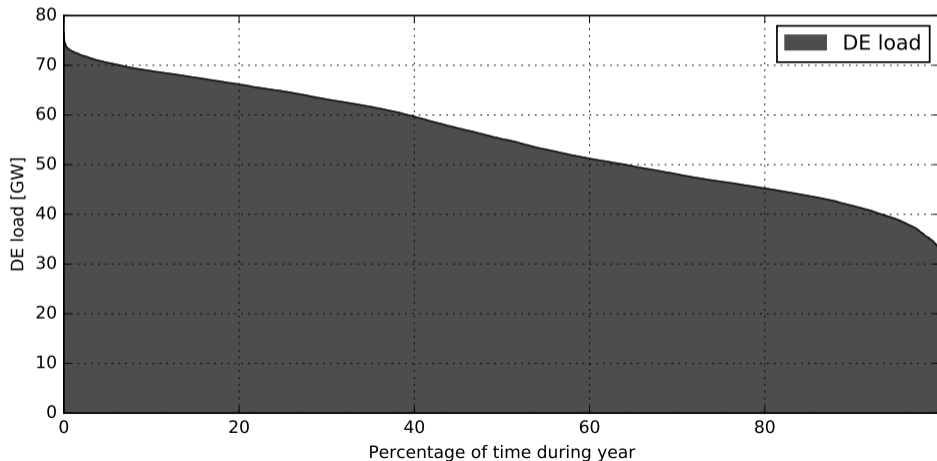

Electricity generation

Conservation of Energy: Energy cannot be created or destroyed: it can only be converted from one form to another.

There are several 'primary' sources of energy which are converted into electrical energy in modern power systems:

- Chemical energy, accessed by combustion (coal, gas, oil, biomass)
- Nuclear energy, accessed by fission reactions, perhaps one day by fusion too
- Hydroelectric energy, allowing water to flow downhill (gravitational potential energy)
- Wind energy (kinetic energy of air)
- Solar energy (accessed with photovoltaic (PV) panels or concentrating solar thermal power (CSP))
- Geothermal energy

At full power, the following items generate:

Item	Power
Solar panel on house roof	15 kW
Wind turbine	3 MW
Coal power station	1 GW

With the exception of solar photovoltaic panels (and electrochemical energy and a few other minor exceptions), all generators convert to electrical energy via rotational kinetic energy and electromagnetic induction in an *alternating current generator*.

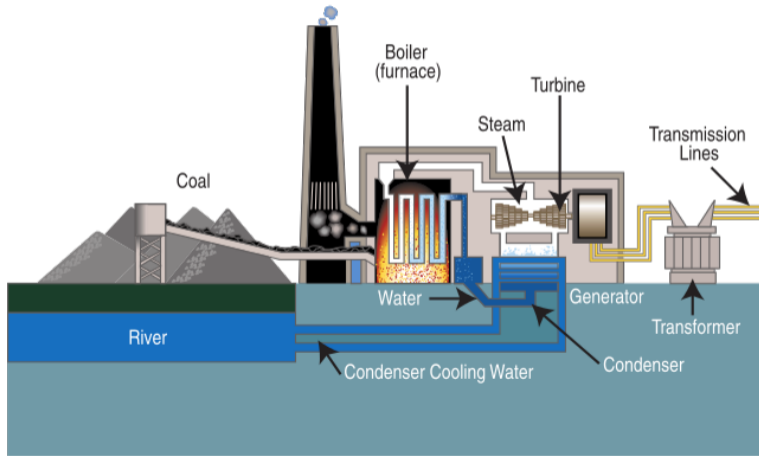

Electricity generation in EU countries in 2022

Electricity generation (TWh, y-axis) and share of electricity (% , x-axis)

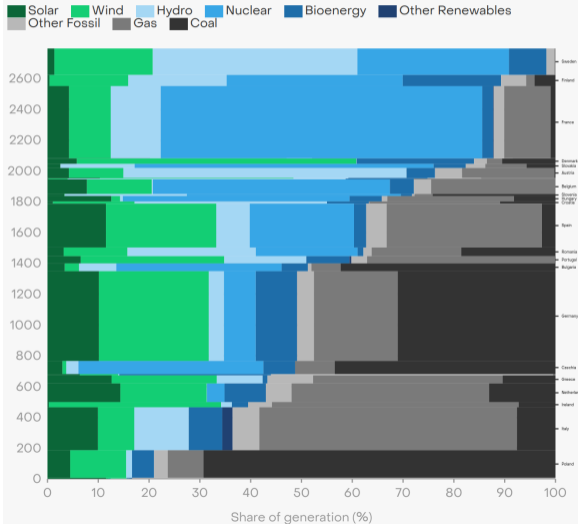

39% (1,104 TWh) of the EU's electricity is generated from coal, gas and other fossil sources. Coal produces 16% (447 TWh), gas 20% (557 TWh) and other fossil fuels 3.6% (100 TWh). Nuclear remains the single largest contributor to EU electricity at 22% (613 TWh) of the mix. 15% (420 TWh) is produced by wind and 7.3% (203 TWh) is produced by solar. Combined, wind and solar produce more electricity than any other fuel (22%, 623 TWh). The rest is produced by hydro (10%, 283 TWh), bioenergy (6%, 167 TWh) and other renewables (0.2%, 6.7 TWh).

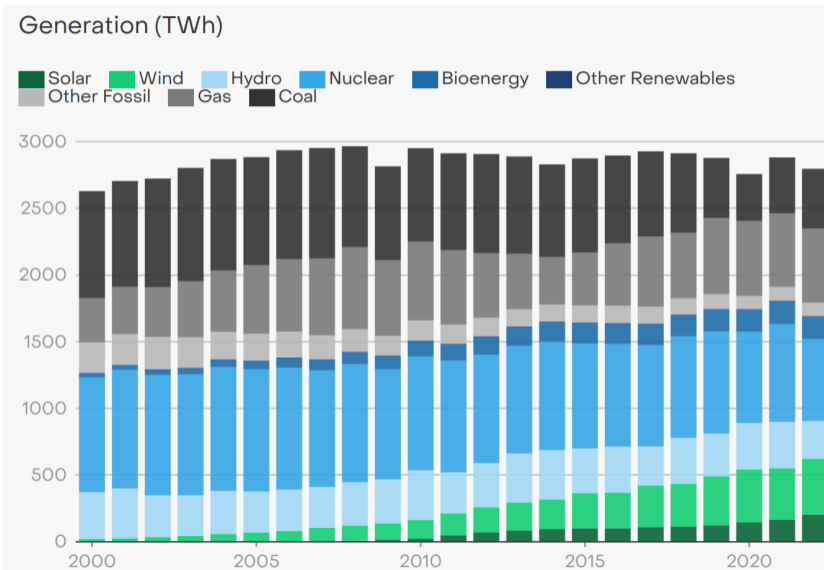

Renewables reached 44.6% of gross electricity in Germany in 2022

Gross power production in Germany 1990 - 2022, by source.

Data: BDEW 2022, data preliminary.

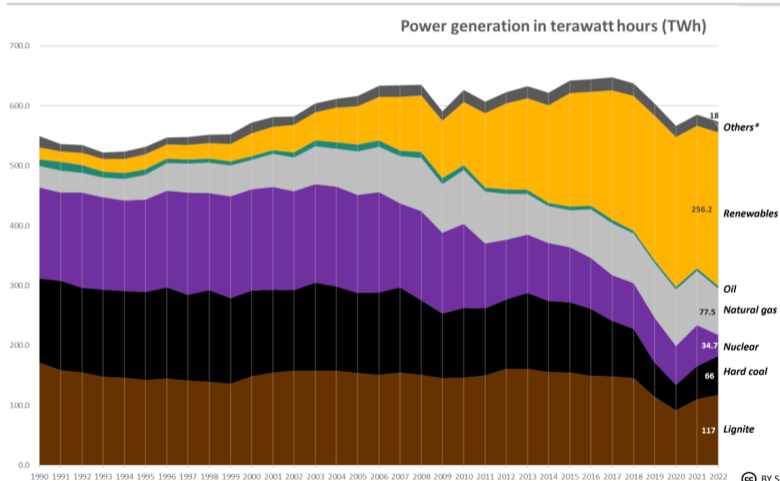

When fuel is consumed, much/most of the energy of the fuel is lost as waste heat rather than being converted to electricity.

The thermal energy, or calorific value, of the fuel is given in terms of MWh_{th} , to distinguish it from the electrical energy MWh_{el} .

The ratio of input thermal energy to output electrical energy is the **efficiency**.

Fuel	Calorific energy MWh_{th}/tonne	Per unit efficiency MWh_{el}/MWh_{th}	Electrical energy MWh_{el}/tonne
Lignite	2.5	0.4	1.0
Hard Coal	6.7	0.45	2.7
Gas (CCGT)	15.4	0.58	8.9
Uranium (unenriched)	150000	0.33	50000

The cost of a fuel is often given in €/kg or €/MWh_{th}.

Using the efficiency, we can convert this to €/MWh_{el}.

For the full marginal cost, we have to also add the CO₂ price and the variable operation and maintenance (VOM) costs.

Fuel	Per unit efficiency MWh _{el} /MWh _{th}	Cost per thermal €/MWh _{th}	Cost per elec. €/MWh _{el}
Lignite	0.4	4.5	11
Hard Coal	0.45	11	24
Gas (CCGT)	0.58	19	33
Uranium	0.33	3.3	10

The CO₂ emissions of the fuel.

Fuel	t _{CO₂} /t	t _{CO₂} /MWh _{th}	t _{CO₂} /MWh _{el}
Lignite	0.9	0.36	0.9
Hard Coal	2.4	0.36	0.8
Gas (CCGT)	3.1	0.2	0.35
Uranium	0	0	0

Current CO₂ price in EU Emissions Trading Scheme (ETS) is around €80-100/tCO₂.

You calculate: What CO₂ price to switch gas and lignite?

What CO₂ price, i.e. $x \text{ €/t}_{\text{CO}_2}$, is required so that the marginal cost of gas (CCGT) is lower than lignite?

NB: It helps to track units.

You calculate: What CO₂ price to switch gas and lignite?

What CO₂ price, i.e. $x \text{ €/tCO}_2$, is required so that the marginal cost of gas (CCGT) is lower than lignite?

NB: It helps to track units.

We need to solve for the switch point by adding the CO₂ price to the fuel cost. Left is lignite, right is gas:

$$11 \text{ €/MWh}_{\text{el}} + (0.9 \text{ tCO}_2/\text{MWh}_{\text{el}}) \cdot (x \text{ €/tCO}_2) = 33 \text{ €/MWh}_{\text{el}} + (0.35 \text{ tCO}_2/\text{MWh}_{\text{el}}) \cdot (x \text{ €/tCO}_2)$$

Solve:

$$x = \frac{33 - 11}{0.9 - 0.35} = 40$$

CO2 and import costs change over time...

Import prices for natural gas, hard coal, and oil, as well as CO₂ certificate prices

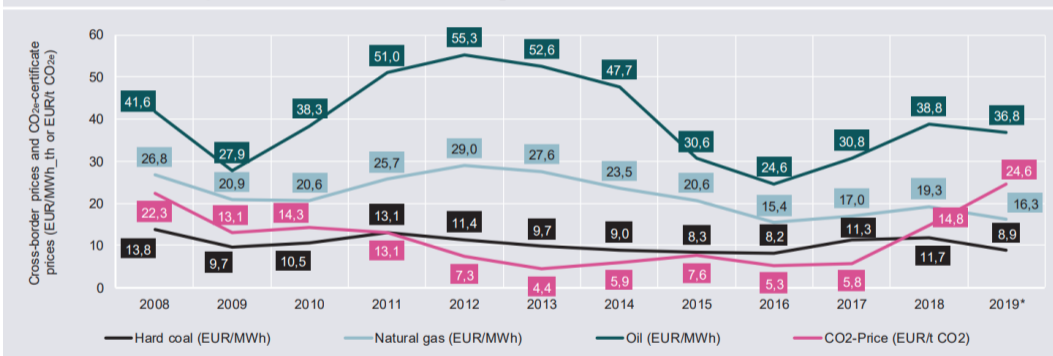

...which affects the marginal costs of generation

Marginal costs for new natural-gas power plants and old power plants fired with lignite and hard coal

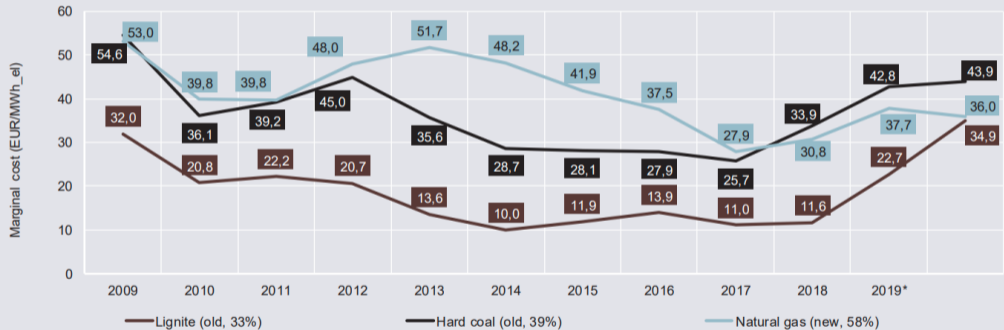

CO₂ emissions in electricity generation stagnated for years because of coal, which is slowly being pushed out by the CO₂ price and in the longer term by the Kohleausstieg.

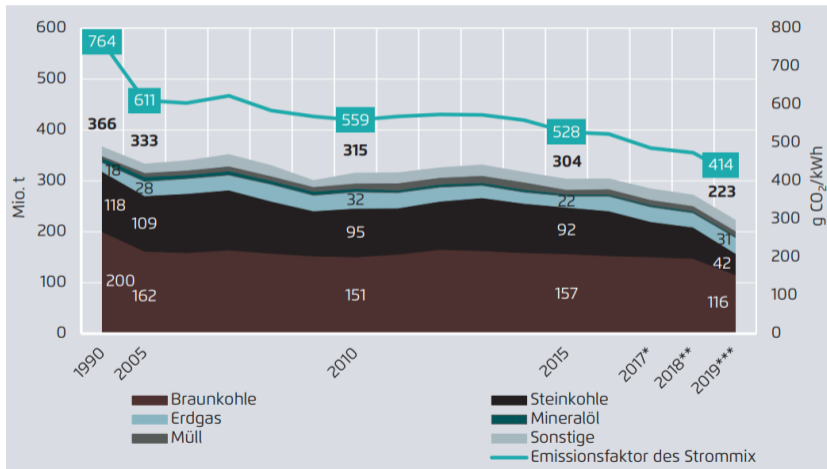

A generator's **capacity factor** is the average power generation divided by the power capacity.

For variable renewable generators it depends on weather, generator model and curtailment; for dispatchable generators it depends on market conditions and maintenance schedules.

A generator's **full load hours** are the equivalent number of hours at full capacity the generator required to produce its yearly energy yield. The two quantities are related:

$$\text{full load hours} = \text{per unit capacity factor} \cdot 365 \cdot 24 = \text{per unit capacity factor} \cdot 8760$$

Typical values for Germany:

Fuel	capacity factor [%]	full load hours
wind	20-35	1600-3000
solar	10-12	800-1000
nuclear	70-90	6000-8000
open-cycle gas	20	1500

Matching consumption to generation

Electricity markets have several important differences compared to other commodity markets.

At every instant in time, consumption must be balanced with generation.

If you throw a switch to turn on a light, somewhere a generator will be increasing its output to compensate.

If the power is not balanced in the grid, the power supply will collapse and there will be blackouts.

It is not possible to run an electricity market for every single second, for practical reasons (the network must be checked for stability, etc.).

So electricity is traded in blocks of time, e.g. hourly, 14:00-15:00, or quarter-hourly, 14:00-14:15, well in advance of the time when it is actually consumed (based on forecasts).

Additional markets trade in backup balancing power, which step in if the forecasts are wrong.

Baseload versus Peaking Plant

Load (= Electrical Demand) is low during night; in Northern Europe in the winter, the peak is in the evening. To meet this load profile, **baseload** generation with low fuel and running costs runs the whole time; more expensive **peaking plant** covers the difference.

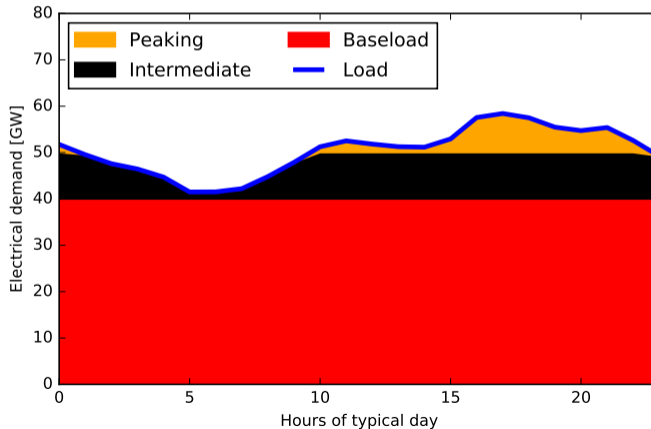

The **merit order** is the arrangement of generation capacities by marginal costs, i.e. the electricity inverse supply function. As long as there is sufficient capacity in the market, the market clearing price equals the marginal cost of the last (i.e. most expensive) generation unit required to match the load.

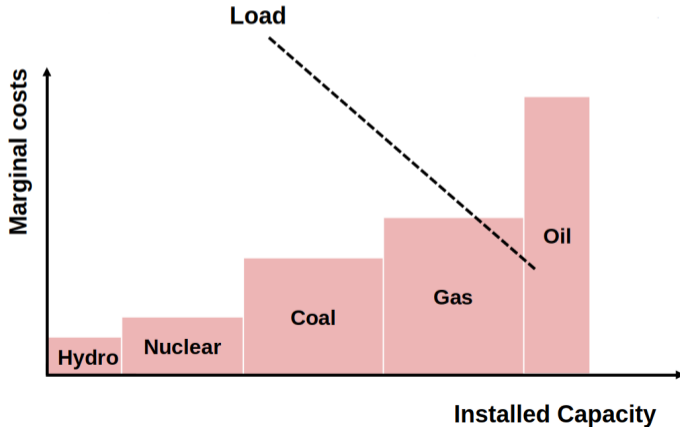

Merit order: effect of varying demand for fixed generation

As demand rises, so does the market clearing price.

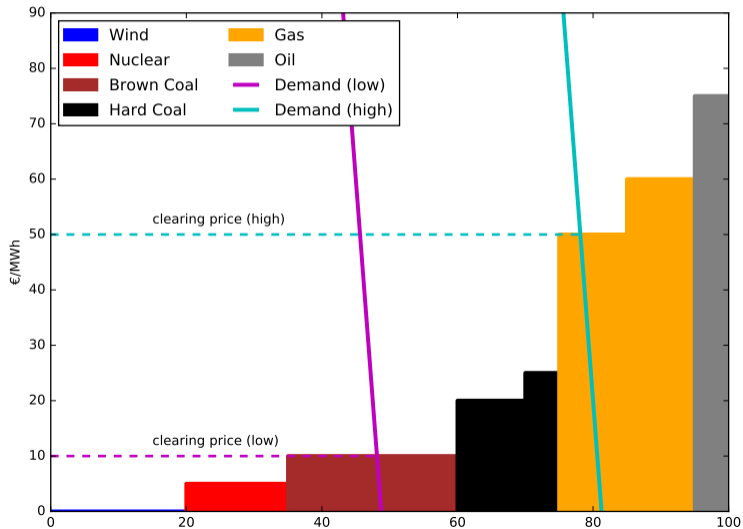

At energy-charts.de you can see the forecast of load, wind, solar and conventional generation right now in Germany, here's an old version:

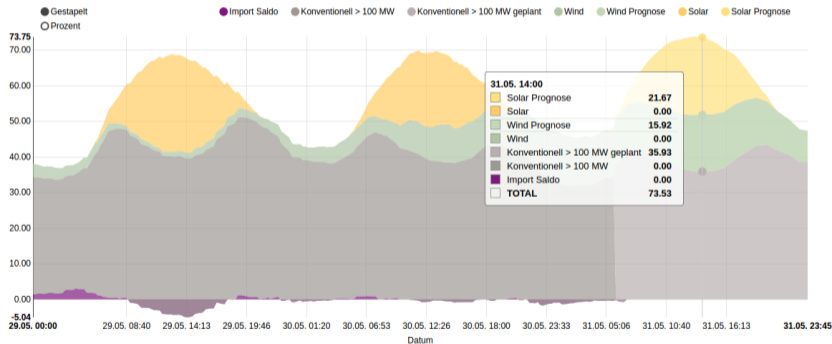

Supply-Demand Curve Real Example

At epexspot.com you can find the real supply-demand curves for every hour, here's an old example for Germany-Austria from 2017:

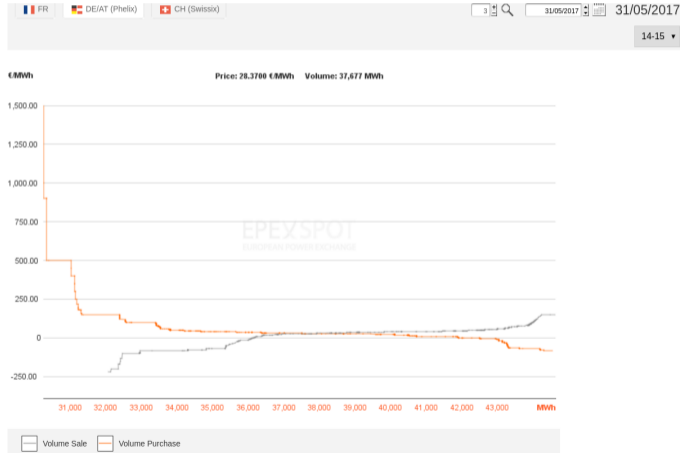

Duration curve for generation

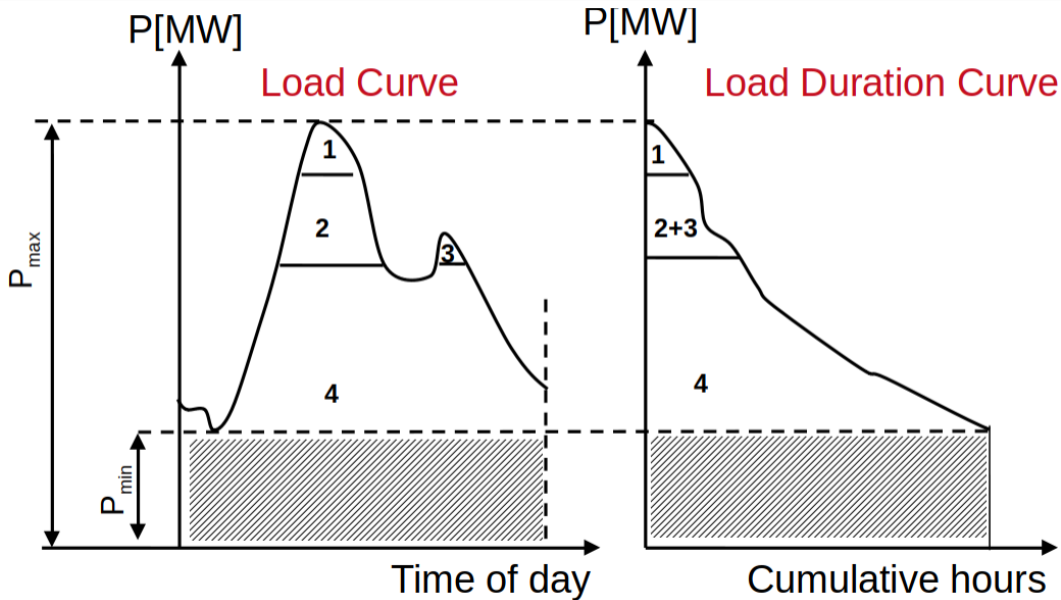

Merit order effect

Example market 1/3

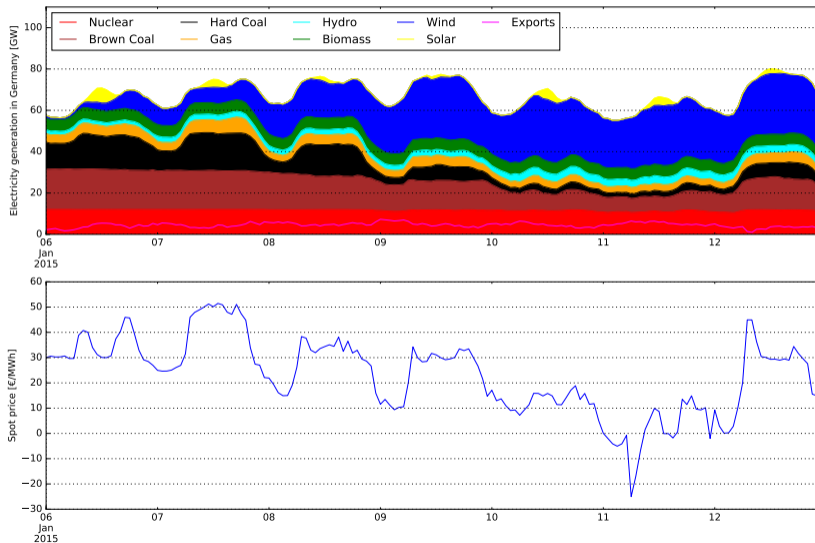

Example market 2/3

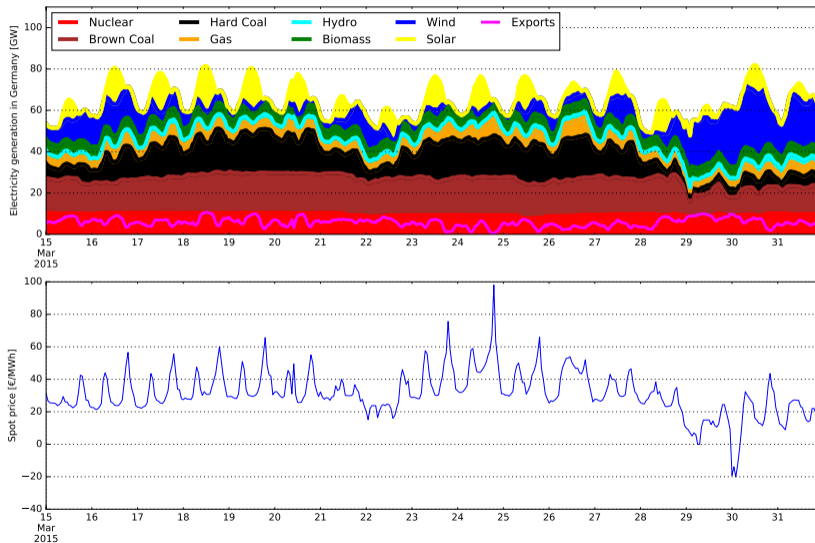

Example market 3/3

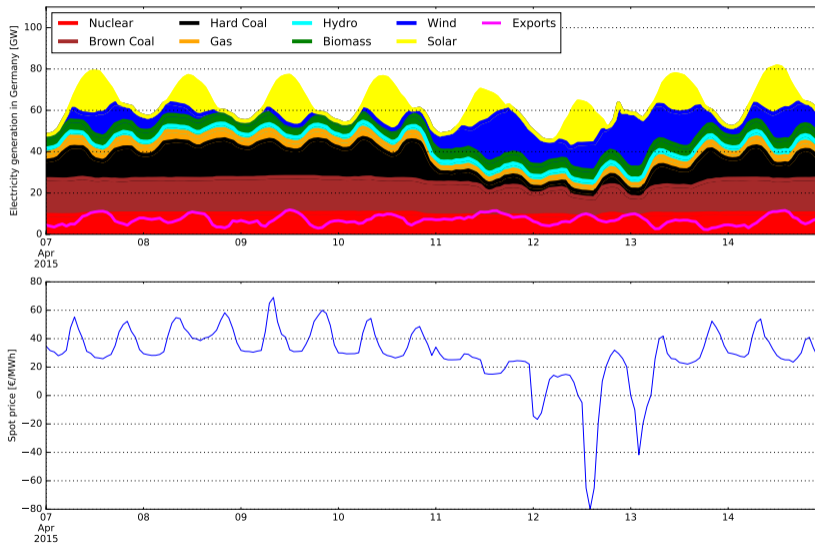

Effect of varying renewables: fixed demand, no wind

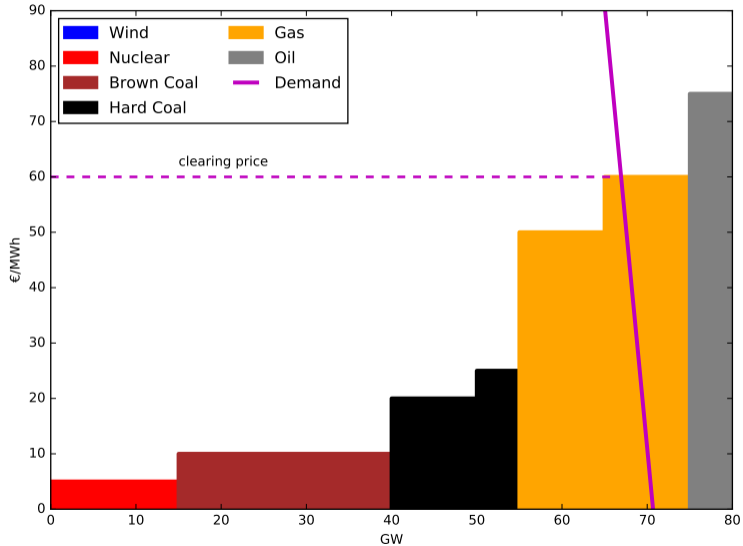

Effect of varying renewables: fixed demand, 35 GW wind

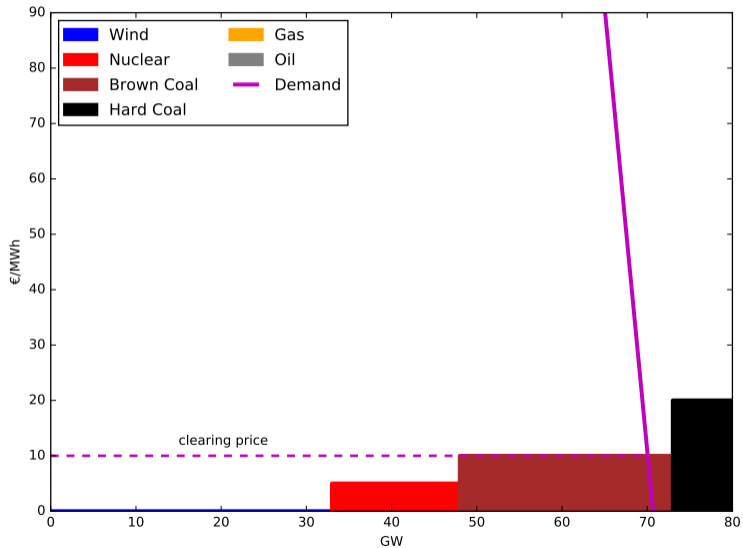

As a result of so much zero-marginal-cost renewable feed-in, spot market prices steadily decreased until 2016. This is called the **Merit Order Effect**. Since then prices have been rising due to rising gas and CO₂ prices.

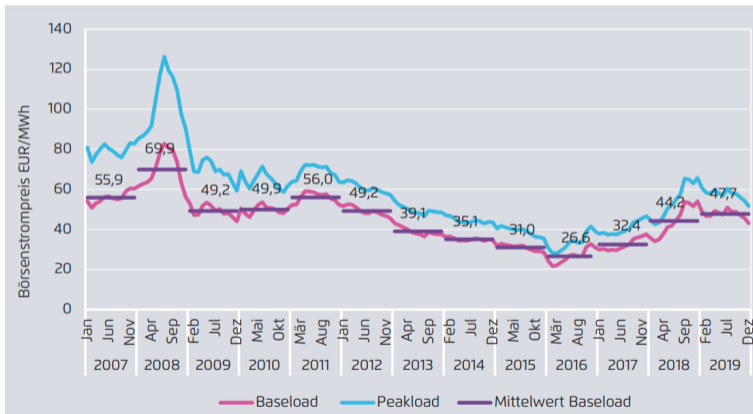

To summarise:

- Renewables have zero marginal cost
- As a result they enter at the bottom of the merit order, reducing the price at which the market clears
- This pushes non-CHP gas and hard coal out of the market
- This is unfortunate, because among the fossil fuels, gas is the most flexible and produces lower CO_2 per MWh_{el} than e.g. lignite
- It also reduces the profits that nuclear and lignite make
- Will there be enough backup power plants for times with no wind/solar?

This has led to lots of political tension, but has been counteracted in recent years by the rising CO_2 price.

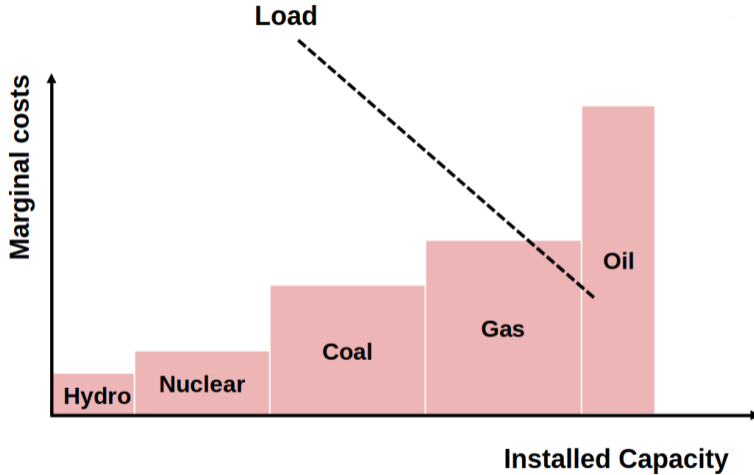

A CO₂ price can alter the merit order (pulling gas before coal) and increase the revenue for low-emission generators like nuclear and renewables.

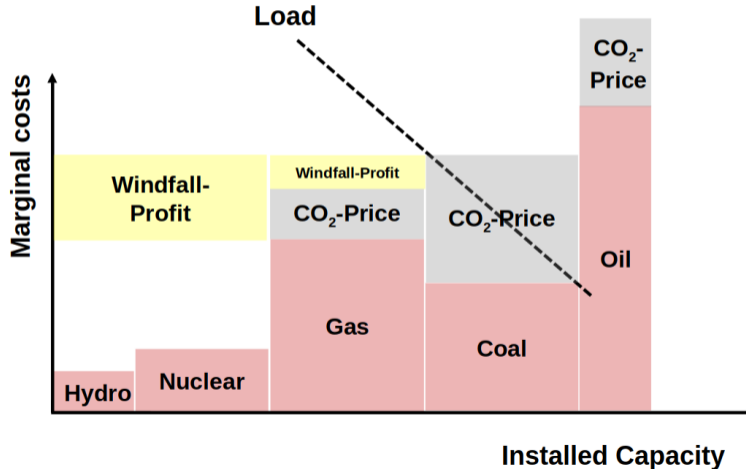

The **residual load** is the regular load minus variable renewable energy (wind and solar). The positive part must be met by dispatchable generators or storage; the negative part must either be curtailed or stored.

